

SPECIFICATION SHEET **FEBCO®**

Series 765

Pressure Vacuum Breakers

Size: 1/2" - 2" (15mm - 50mm)

The FEBCO Series 765 Pressure Vacuum Breakers are used to protect against health hazard and non-health hazard backsiphonage conditions in industrial plants, cooling towers laboratories, laundries, swimming pools and lawn sprinkler systems.

Features

- All bronze body for durability. One check valve and an air opening port in one assembly.
- Lightweight poppet seals air opening under minimum flow conditions.
- Simple service procedures. All internal parts serviceable in line from the top of the unit.
- Designed for minimum head loss.
- Engineered plastic bonnet protect valve bodies from freeze damage.
- Optional union end ball valves for easy removal and ultimate freeze protection.
- End Connections – NPT ANSI/ASME B1.20.1

Operation

The FEBCO 765 PVB is designed to be installed to provide protection against backsiphonage of toxic or non-toxic liquids. It consists of a spring loaded check valve which closes tightly when the pressure in the assembly drops below 1psi or when zero flow occurs, plus, an air relief valve that opens to break a siphon when the pressure in the assembly drops to 1psi.

Specifications

Pressure Vacuum Breaker assemblies shall be installed to withstand pressure for long periods and to prevent backflow of contaminated water into the potable water system in backsiphonage conditions. The Pressure Vacuum Breaker assembly shall consist of a single spring loaded check valve which closes tightly when water flow through the assembly drops to zero, and a single air relief valve that opens to break the siphon when pressure drops to 1psi. The assembly shall include two resilient seated shut-offs and two resilient seated test cocks, considered integral to the assembly. Assemblies must be factory backflow tested. The check valve and air inlet valve must be constructed to allow in-line servicing of the assembly. The valve body shall be constructed of bronze. The check, poppet and bonnet assembly shall be constructed of engineered plastic to protect the valve body from freeze damage.

Pressure Vacuum Breaker assemblies shall be installed a minimum of 12" (300mm) above the highest downstream outlet, and the highest point in the downstream piping. The assembly shall be rated to 150psi working pressure and water temperature from 32°F to 140°F. The assembly shall meet the specifications of the USC FCCC & HR Manual.

Pressure Vacuum Breaker assemblies shall be FEBCO Series 765 or prior approved equal.

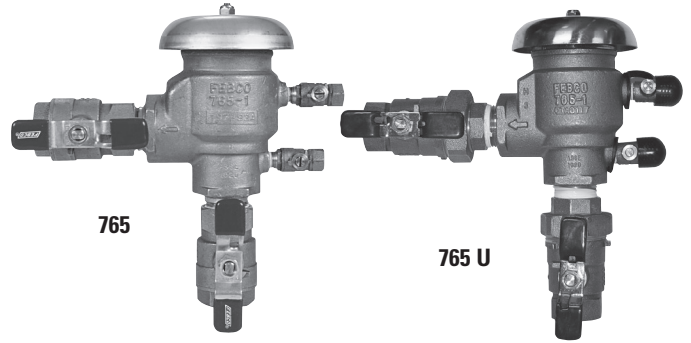

Approvals – Standards

- Approved by the Foundation for Cross-Connection Control and Hydraulic Research at the University of Southern California.



Applications

PVB assemblies are used to protect against health hazard and non-health hazard backsiphonage conditions in industrial plants, cooling towers laboratories, laundries, swimming pools and lawn sprinkler systems.

Typical Installation

Pressure Vacuum Breaker assemblies should be installed at least 12" (300mm) above the highest piping and outlet downstream of the assembly to preclude backpressure. Assemblies should be installed so they are easily accessible for maintenance, periodic testing, and where discharge will not be objectionable. They should be protected from freezing. If the assemblies are subject to freezing temperatures, the freeze protection procedures outlined in "Service Instruction Freeze Protection Model 765" must be followed. Assemblies must not be installed where backpressure could occur.

The discharge pressure shall be maintained above 3.0psi on 1/2" - 1 1/4" (15 - 32mm) sizes and 5.0psi on 1 1/2" - 2" (40 - 50mm) sizes to insure seating of the spring loaded air inlet poppet.

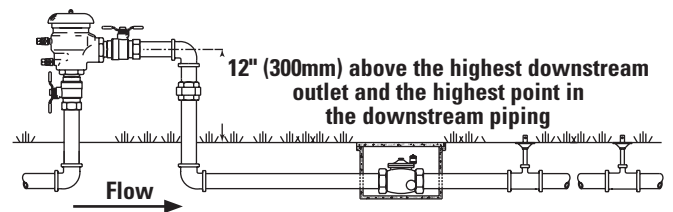

Thermal water expansion and/or water hammer down stream of the backflow preventer can cause pressure increases. Excessive pressure should be eliminated to avoid possible damage to the system and assembly.

Job Name _____

Job Location _____

Engineer _____

Approval _____

Contractor _____

Approval _____

Contractor's P.O. No. _____

Representative _____

FEBCO product specifications in U.S. customary units and metric are approximate and are provided for reference only. For precise measurements, please contact FEBCO. FEBCO reserves the right to change or modify product design, construction, specifications, or materials without prior notice and without incurring any obligation to make such changes and modifications on FEBCO products previously or subsequently sold.

Pressure – Temperature

Max. Working Pressure:	150psi (10.3 bar)
Hydrostatic Test Press:	300psi (20.7 bar)
Temperature Range:	32°F to 140°F (0°C to 60°C)

Materials

Main Valve Body:	Bronze
Elastomers:	Nitrile

Models

- Union End Ball Valves

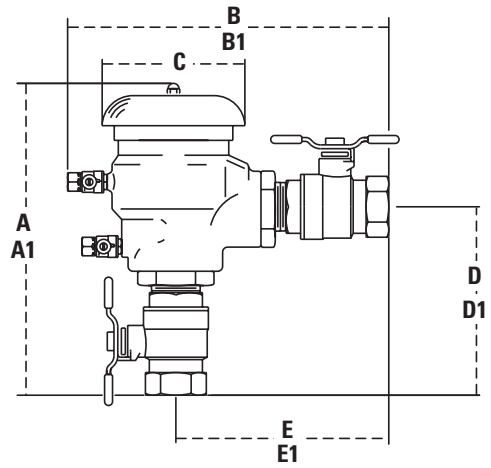

Dimensions – Weights

Size: ½" - 2" (15 - 50mm)

SIZE (DN)		DIMENSIONS																		WEIGHT	
in.	mm	A		A1 (union)		B		B1 (union)		C		D		D1 (union)		E		E1 (union)		lbs.	kgs.
		in.	mm	in.	mm	in.	mm	in.	mm	in.	mm	in.	mm	in.	mm	in.	mm	in.	mm		
½	15	6¼	159	7	178	6¾	172	7½	197	2½	64	¾	95	4½	114	¼	108	5	127	2.6	1.2
¾	20	6½	165	7⅞	187	7	178	7⅞	200	2½	64	4	102	4⅞	124	½	114	5⅞	137	2.9	1.3
1	25	8¾	222	9⅝	245	9	229	9⅝	252	4	102	5¼	133	6⅜	157	6	152	6⅝	176	5.9	2.7
1¼	32	9¼	235	10¼	260	10	254	11	279	4	102	6¼	159	7¼	184	7	178	8	203	7.0	3.2
1½	40	11¾	299	12⅞	327	11½	292	12⅞	321	6½	165	7¼	184	8⅞	213	7¾	197	8¾	225	14.8	6.7
2	50	12½	318	13¾	349	12¼	311	13½	343	6½	165	8	203	9¼	235	8½	216	9¾	248	16.5	7.5

Note: Weights shown do not include union end ball valves and are approximate. Dimensions shown are nominal, allowance must be made for normal manufacturing tolerances.

Capacity

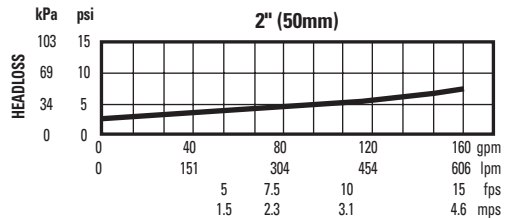
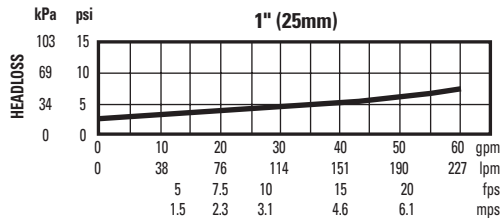
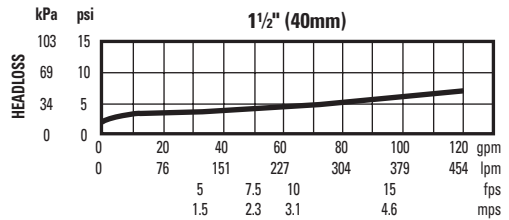
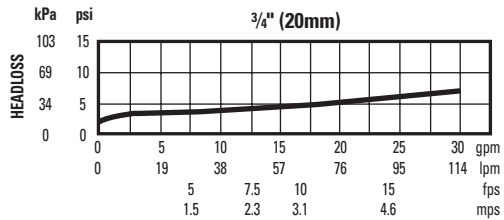
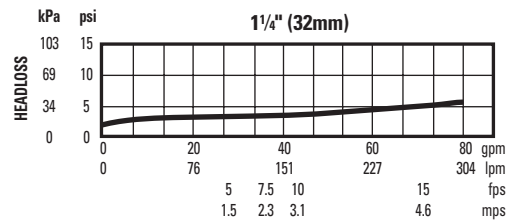
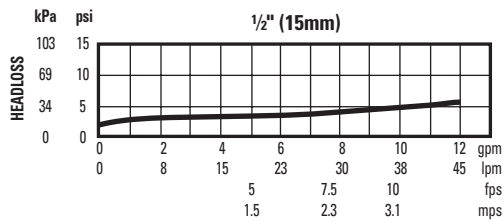

A Watts Water Technologies Company



ISO 9001-2000
CERTIFIED

USA: 4381 N. Brawley • Ste. 102 • Fresno, CA • 93722 • Tel. (559) 441-5300 • Fax: (559) 441-5301 • www.FEBCOonline.com
Canada: 5435 North Service Rd. • Burlington, ONT. • L7L 5H7 • Tel. (905) 332-4090 • Fax: (905) 332-7068 • www.FEBCOonline.ca